



## Teldat Router Connect-104V

Teldat-Dm 582-I

Copyright© Version 1.4 02/2020 Teldat S.A.

## **Legal Notice**

### **Warranty**

This publication is subject to change.

Teldat S.A. offers no warranty whatsoever for information contained in this manual.

Teldat S.A. is not liable for any direct, indirect, collateral, consequential or any other damage connected to the delivery, supply or use of this manual.

# Table of Contents

Chapter 1	About This Manual . . . . .	1
1.1	Supported Devices . . . . .	1
1.2	Who should read this manual? . . . . .	1
1.3	When should this manual be read? . . . . .	1
1.4	What is in this manual? . . . . .	1
1.5	What is not in this manual? . . . . .	1
1.6	How is the information organized? . . . . .	1
1.7	Technical Support . . . . .	1
1.8	Related Documentation . . . . .	2
Chapter 2	Teldat Connect 104V Device. . . . .	3
2.1	Features. . . . .	3
2.1.1	Power supply . . . . .	3
2.1.2	Hardware Monitoring . . . . .	3
Chapter 3	Components and Power Supply . . . . .	4
3.1	Components . . . . .	4
3.1.1	Front Panel . . . . .	4
3.1.2	Rear Panel . . . . .	4
3.1.3	Side Panels . . . . .	5
3.1.4	Bottom Panel . . . . .	5
3.1.5	Top Panel (LEDs). . . . .	6
3.2	Rack mounting . . . . .	7
3.2.1	Standalone . . . . .	7
3.2.2	Wall mounting . . . . .	7
3.3	Plug-in Modules . . . . .	9
3.3.1	Installation. . . . .	9
3.3.2	Removal. . . . .	9
3.4	Power Source . . . . .	9
3.4.1	Connecting the Power Supply . . . . .	10
3.4.2	Connecting . . . . .	10
3.4.3	Disconnecting . . . . .	10
3.5	RST Button . . . . .	10
3.5.1	Rebooting the device . . . . .	10
3.5.2	Default Configuration . . . . .	10
3.6	Connecting the data. . . . .	11
3.6.1	4-port Ethernet Switch. . . . .	11

3.6.2	WAN Connection . . . . .	11
3.6.3	DSL Connection . . . . .	12
3.6.4	WWAN Antenna Connection (Cell connector). . . . .	13
3.6.5	Wireless LAN Antenna Connection (Wi-Fi connectors) . . . . .	14
3.6.6	Connecting a 3G USB (USB connector) . . . . .	14
3.7	Installing the SIM card. . . . .	15
<b>Appendix A</b>	<b>Model information. . . . .</b>	<b>17</b>
<b>Appendix B</b>	<b>Appendix . . . . .</b>	<b>18</b>
B.1	Troubleshooting . . . . .	18
B.2	Updating the software . . . . .	18
B.3	Connectors . . . . .	19
B.3.1	LAN Connector . . . . .	19
B.3.2	WAN Connector . . . . .	19
B.3.3	WWAN/Cell Connector (female) . . . . .	19
B.3.4	WLAN/Wi-Fi Connector (male) . . . . .	20
B.3.5	DSL Connector . . . . .	20
B.3.6	USB Connector. . . . .	20
B.3.7	Configuration Connector . . . . .	21
B.3.8	Power Supply Connector . . . . .	21
B.4	Technical Specifications . . . . .	21
B.4.1	Hardware Architecture. . . . .	21
B.4.2	LAN Interface . . . . .	21
B.4.3	WAN Interface . . . . .	21
B.4.4	DSL Interface . . . . .	22
B.4.5	Wireless WAN Interface . . . . .	22
B.4.6	Wireless LAN Interface . . . . .	22
B.4.7	USB Interface . . . . .	22
B.4.8	Configuration Interface . . . . .	22
B.4.9	Power Supply . . . . .	23
B.4.10	External Power Supply . . . . .	23
B.4.11	Dimensions and weight . . . . .	23
B.4.12	Environmental Specifications. . . . .	23
<b>Appendix C</b>	<b>Regulatory compliance and Safety information . . . . .</b>	<b>24</b>
C.1	Translated Safety Warnings . . . . .	24
C.2	PSU Energy Efficiency . . . . .	24
C.3	Compliance . . . . .	25
C.3.1	FCC Statement. . . . .	25

# Chapter 1 About This Manual

This is the installation manual for the **Teldat Connect 104V** router family and contains information on how to correctly install devices in a working environment.

## 1.1 Supported Devices

The information contained herein only applies to the **Teldat Connect 104V** TLDPV00A1 / TLDPV01A1 / TLDPV02A1 router models.

## 1.2 Who should read this manual?

This manual should be read by support personnel who need to install, configure, maintain and monitor the device.

## 1.3 When should this manual be read?

Read this manual as soon as you are ready to familiarize yourself with the device and its components.

This manual will give you a better understanding of your new device.

## 1.4 What is in this manual?

This installation guide contains the following information:

- A description of the features available on **Teldat Connect 104V** routers.
- Technical specifications.
- Power supply requirements.
- Elements that can be connected when the router is operating.
- Installing and removing modules and power sources.
- A description of the device LEDs and connectors.
- Troubleshooting.

## 1.5 What is not in this manual?

This manual does not contain information about the device software or its configuration. For information on how to configure the device, please see the relevant protocol manuals found in the Teldat website: [www.teldat.com](http://www.teldat.com).

## 1.6 How is the information organized?

Each chapter focuses on a specific part of the hardware and its components. All descriptive and technical specifications, together with information on a component, can be found in the relevant chapter.

## 1.7 Technical Support

Teldat, S.A. offers technical support. Device software can be upgraded on a regular basis for maintenance purposes, as well as when new features are developed.

Contact information:

Web: [www.teldat.com](http://www.teldat.com)

Tel.: +34 918 076 565

Fax: +34 918 076 566

Email: [support@teldat.com](mailto:support@teldat.com)

## 1.8 Related Documentation

Dm741-I *ADSL- VDSL2*

Dm748-I *Software Updating*

Dm781-I *Cellular Interface*

## Chapter 2 Teldat Connect 104V Device

### 2.1 Features

#### 2.1.1 Power supply

For further information on the different power supplies supported by the **Teldat Connect 104V** router family, please see [Power Source](#) on page 9 and [Components and Power Supply](#) on page 4.

#### 2.1.2 Hardware Monitoring

The LED panel is the only way to monitor the hardware in the **Teldat Connect 104V** router. These LEDs provide visual information on the state of the device and reference the condition of the hardware components, indicating whether there is connectivity, data flow, etc.

For further information on the LED panel, please see [Components](#) on page 4 in the following chapter.

## Chapter 3 Components and Power Supply

The following chapter provides detailed information on the chassis of the **Teldat Connect 104V** router and its components. This information includes:

- Components.
- Information on assembly.
- Installing and removing modules.
- Power supply.
- RST button.
- Data connection.
- SIM card installation.

### 3.1 Components

#### 3.1.1 Front Panel

The following figure shows the front panel and the wireless cellular WAN (WWAN) antenna connectors located there.

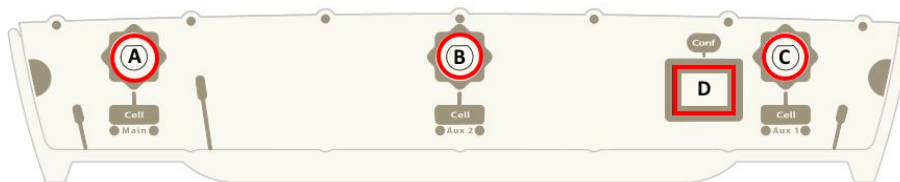

Fig. 1: Front panel

The front panel elements include:

##### Front panel elements

Item	Description
A	Main antenna for the <b>Teldat Connect 104V</b> cellular module.
B	Auxiliary antenna 2 for the <b>Teldat Connect 104V</b> cellular module.
C	Auxiliary antenna 1 for the <b>Teldat Connect 104V</b> cellular module.
D	RJ-45 connector providing access to the <b>Teldat Connect 104V</b> local console for configuring and monitoring purposes.

#### 3.1.2 Rear Panel

The following figure shows the rear panel. Here you can see the remaining **Teldat Connect 104V** connectors.

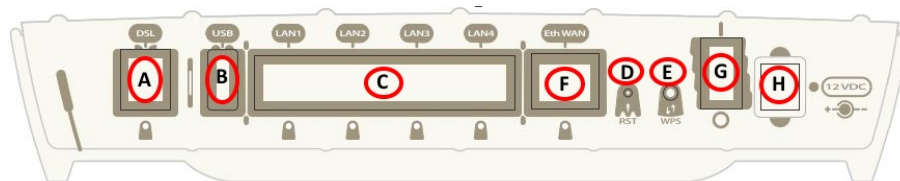

Fig. 2: Rear panel

The following table provides information on each connector, together with a description:



### Rear panel elements

Item	Description
A	DSL. DSL connector.
B	USB. Slot to insert a 3G/WWAN USB modem.
C	4-port Gigabit Ethernet Switch.
D	RST. Reset button. Please see <a href="#">RST Button</a> on page 10 in this chapter for more information on how the reset button works.
E	WPS (Wireless Protected Setup). This allows for an easy and secure configuration of the Wi-Fi network parameters.
F	Eth WAN. Gigabit Ethernet WAN.
G	On/Off switch.
H	Power source connection (PSU).

### 3.1.3 Side Panels

Each side panel contains one Wi-Fi antenna.



Fig. 3: Right side panel



Fig. 4: Left side panel

### 3.1.4 Bottom Panel

The following elements can be found on the bottom panel:

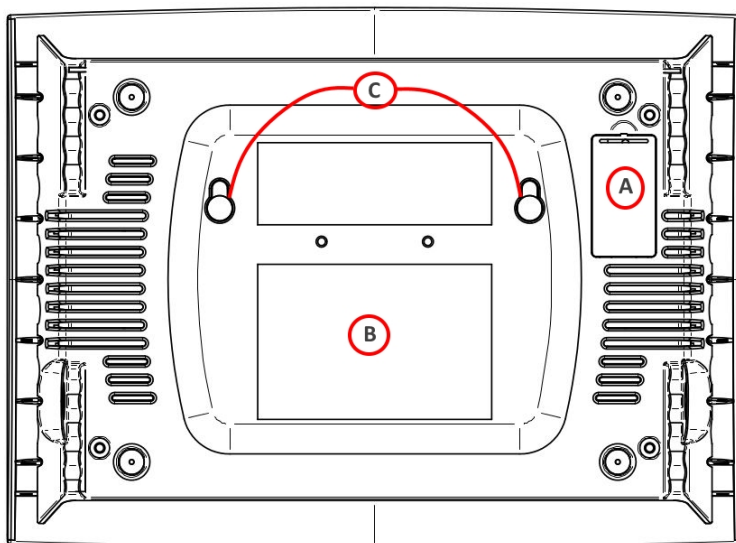

Fig. 5: Bottom panel

The main items on the bottom panel are as follows.

**Bottom panel elements table**

Item	Description
A	SIM tray for internal cellular WWAN. This is accessed from the underside of the router.
B	Platform where the label that contains product information is placed. This label contains information on the device model, mac, serial number, etc.
C	Slots for wall mounting.

**3.1.5 Top Panel (LEDs)**

The LED panel provides information on the status of the components (whether or not they are active) and on network activity.

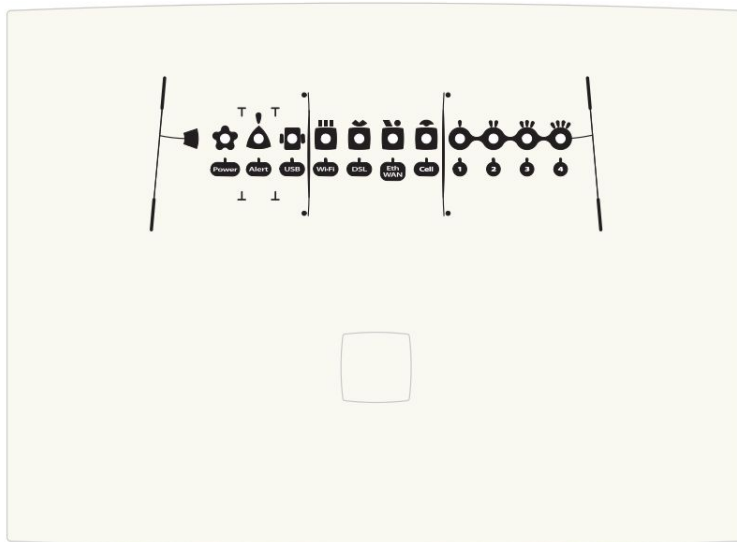

Fig. 6: LED panel

The **Teldat Connect 104V** LEDs are shown in the above figure. The below table contains a description of each one.

**LED table**

LED	State	Description
Power	Monochrome	Off -> not receiving power from PSU.
	Green	On -> receiving power from PSU.
Alert	Monochrome Green	On -> when software is running.
USB	Tricolor	Off -> system is powered off.
		Red -> interface not available, not supported or auto-test failure.
		Amber -> idle.
		<ul style="list-style-type: none"> <li>• Rapid blinking. It hasn't registered in the network or the quality is insufficient.</li> <li>• Slow blinking. GSM connection (GPRS).</li> <li>• Steady. WCDMA (UMTS/HSDPA) or LTE connection.</li> </ul>
		Green -> connected. Blinking: connection data activity.
Wi-Fi	Bicolor	Red -> interface down.
		Green -> interface up.

		Blinking (green/red) -> activity/maintenance.
DSL	Monochrome Green	Slow blinking -> link not established. Rapid blinking -> the link is being established. Steady -> link established.
Eth WAN	Tricolor	Green -> connected. Blinking: connection data activity. Amber -> blinking, auto-test. Red -> disconnected.
Cell	Tricolor	Off -> system is powered off. Red -> interface not available, not supported or auto-test failure. Amber -> idle. <ul style="list-style-type: none"> <li>• Rapid blinking. It hasn't registered in the network or the quality is insufficient.</li> <li>• Slow blinking. GSM connection (GPRS).</li> <li>• Steady. WCDMA (UMTS/HSDPA) or LTE connection.</li> </ul> Green -> connected. Blinking: connection data activity.
Coverage (1, 2, 3, 4)	Monochrome blue	Indicates the current coverage level for the internal cellular WWAN module. 0 level (all LEDs off) to 4 (all LEDs on).

## 3.2 Rack mounting

The **Teldat Connect 104V** router cannot be mounted in a rack. It can, however, be mounted on a wall or simply left as a standalone.

### 3.2.1 Standalone

The **Teldat Connect 104V** router can be placed as a standalone on a flat, stable surface.

Make sure there is enough space around the router (for ventilation purposes) and check that the power cord can reach it.

### 3.2.2 Wall mounting

The **Teldat Connect 104V** router can be mounted on a wall.

Two slots on the underside of the device help fix it to the wall. See [Bottom Panel](#) on page 5.

The screws and wall anchors are not included with the device and must be purchased separately. We recommend you use the following accessories for wall mounting, since they are valid for both a solid and a plaster (Gypsum board) wall:

- 2 screws: [COACH SCREW HEAD 90 DEGR.POZIDR. 3.5 x 30]



Fig. 7: Screw

- 2 wall anchors: [WHITE STRIATED WALL ANCHOR DIAM.8mm]



Fig. 8: Wall anchor



**Warning**

The screws must go into a wall stud (wood) or a wall anchor of the appropriate type for the wall. Screws into drywall are not strong enough to support the router.

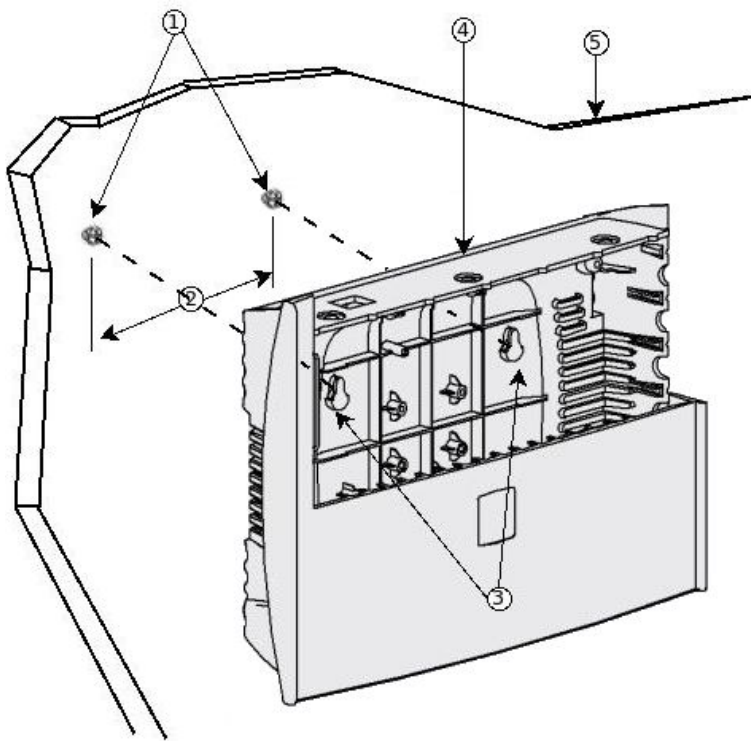

Fig. 9: Teldat Connect 104V wall-mounting features

The above figure shows the Teldat Connect 104V wall-mounting features.

1	Wall screws	2	10.2 cm (4.02 inches)
3	Chassis mounting slots (on underside)	4	Router chassis
5	Mounting surface		

To mount the router on a wall, or any other surface, carry out the following:

**Step 1:** Install the two screws (3.5 x 30) horizontally and separately in a wall or any other vertical surface.

The screws should protrude 0.6 cm (0.25 inch) from the wall surface.



#### Warning

If you install the screws in drywall, use hollow-wall anchors (8 mm – 5/16 inch) to secure the screws. If the screws are not properly anchored, the strain of the cables connected to the router back panel could pull the router from the wall.

**Step 2:** Hang the router on the screws. (See Figure 9)



#### Note

- The accessories for wall mounting are not provided with the router and must be purchased separately.
- The wall-mounting accessories must be those recommended for the type of wall. You need to make sure that they are able to support the weight of the router.

## 3.3 Plug-in Modules

Presently, only the 3G USB/WWAN module is supported. To view the full list of supported 3G/WWAN modules, please visit the following website: [www.teldat.com](http://www.teldat.com).

### 3.3.1 Installation

To install the USB modem, simply plug it in the USB slot (found on the rear panel), as shown in Figure 10.

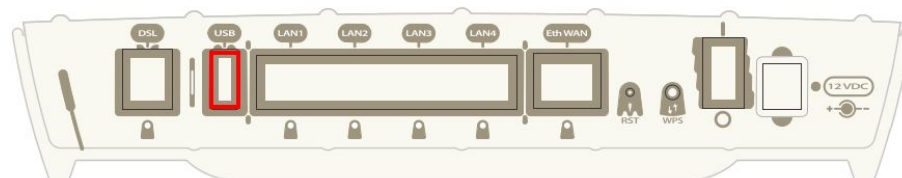

Fig. 10: USB modem insertion slot

### 3.3.2 Removal

To remove the device, simply unplug it from the slot where it is inserted. See Figure 10.

## 3.4 Power Source

The **Teldat Connect 104V** router is powered through an external AC/DC power source.



#### Warning

The equipment must be used with the power supply provided by the manufacturer, or equivalent.

#### Workplace conditions. Main characteristics

- Avoid humid and/or dusty locations.
- Avoid direct exposure to sunlight and other heat sources. Do not place the device amongst papers, magazines or other items that could hinder natural air circulation.
- Do not place the device near strong electromagnetic fields such as those produced by speakers, motors, etc.
- Avoid knocks and/or strong vibrations during operation, storage and transport.

**Warning**

The electric current in power cables, telephone lines and communication cables is dangerous. To prevent electric shocks, before installing, handling or opening the equipment covers, connect and disconnect the cables following the steps set forth in *Connecting* on page 10 and *Disconnecting* on page 10.

### 3.4.1 Connecting the Power Supply

To connect the power supply to the device, please follow the steps listed in *Connecting* on page 10.

To avoid electric shocks, residual current circulation and any other unwanted effects that may disrupt communication, the following is recommended:

**Warning**

All interconnected communication devices should be plugged to THE SAME GROUNDED POWER OUTLET, which should at the same time be of good quality (lower than 10 ohms).

Whether the workplace is provided with an uninterrupted power supply system (UPS), regulated supply or it is independent from the rest (such as lighting, etc.); it is highly recommended that all data devices should be connected to the same power source. This will avoid operating and premature aging problems of drivers and other components.

### 3.4.2 Connecting

- Make sure the device's power supply switch is in the OFF position (0).
- Ensure that the power supply is NOT connected to the mains or to the device.
- Connect all data cables.
- Connect the power supply to the device.
- Connect the power supply to the mains.
- Switch the router's power switch to ON (1).

### 3.4.3 Disconnecting

- Make sure the device's power supply switch is in the OFF position (0).
- Disconnect the power supply from the mains.
- Disconnect the power supply from the device.
- Disconnect the data cables.

## 3.5 RST Button

The different RST button features are described below:

### 3.5.1 Rebooting the device

Once the device is operating normally, pressing the RST button will make it restart.

### 3.5.2 Default Configuration

The RST button allows you to boot the device with its default configuration (factory settings). Please follow these steps:

- With the device switched off, press and hold the RST button down while you turn the router on using the ON/OFF switch (1).

- The Power LED (green) lights up and the USB LED starts blinking (green). This blinking lasts for 10 seconds.
- To boot the device with the default configuration, let go of the RST button while the USB LED is still blinking (i.e. before the 10-second period expires).

The router's default configuration establishes the following IP address and mask:

- IP address: 192.168.1.1
- IP mask: 255.255.255.0



#### Note

Some devices leave the factory with customized settings. This personalization can mean that the default configuration is different from the one shown above.

## 3.6 Connecting the data

The **Teldat Connect 104V** router has the following data connections:

### 3.6.1 4-port Ethernet Switch

The **Teldat Connect 104V** router incorporates a 4-port 10/100/1000 BaseT switch with automatic MDI/MDIX to connect to a local area network (LAN).

Please pay careful attention to the labeling to avoid confusing the switch with other port types:

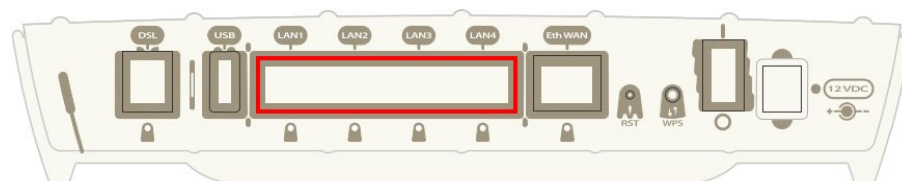

Fig. 11: LAN switch ports



#### Note

Only the LAN 1 connector is available during booting and in BIOS mode.

### 3.6.2 WAN Connection

The **Teldat Connect 104V** router incorporates an Ethernet WAN 10/100/1000 BaseT port with automatic MDI/MDIX.

The WAN port is independent of the switch and is operated just like any other interface.

Please pay careful attention to the labeling to avoid confusing the switch with other port types.

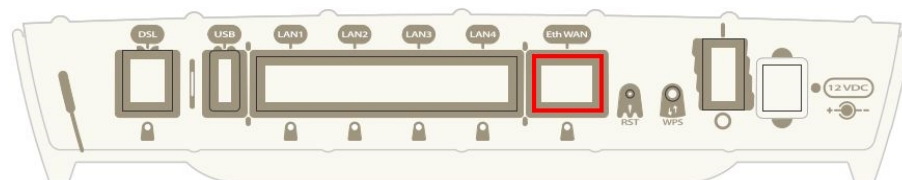

Fig. 12: WAN port



#### Note

The Eth WAN connector is not operative during booting and in BIOS mode.

### 3.6.3 DSL Connection

The **Teldat Connect 104V** router has a DSL connector to connect to a VDSL2/ADSL network. **The central pair** of this 4-wire female RJ11 connector is used for data transmission/reception.

For connection purposes, use the telephone cable with male RJ11 connectors provided with the router.

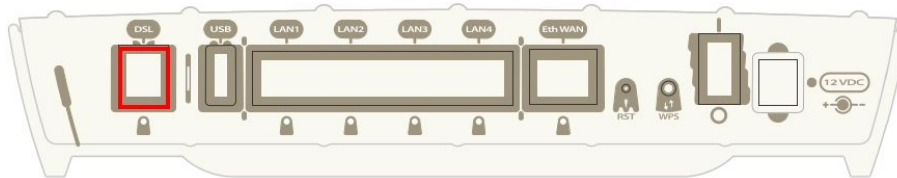

Fig. 13: DSL port (VDSL2/ADSL)

#### The splitter

By default, the supported modes do not allow the basic service device (PSTN or ISDN depending on the model) to be directly connected to the same line; you need to use a **splitter**, a device that separates the basic service frequencies band from those used by DSL, thus avoiding interferences between the telephone and DSL services.

A typical installation with a splitter is shown in Figure 14.

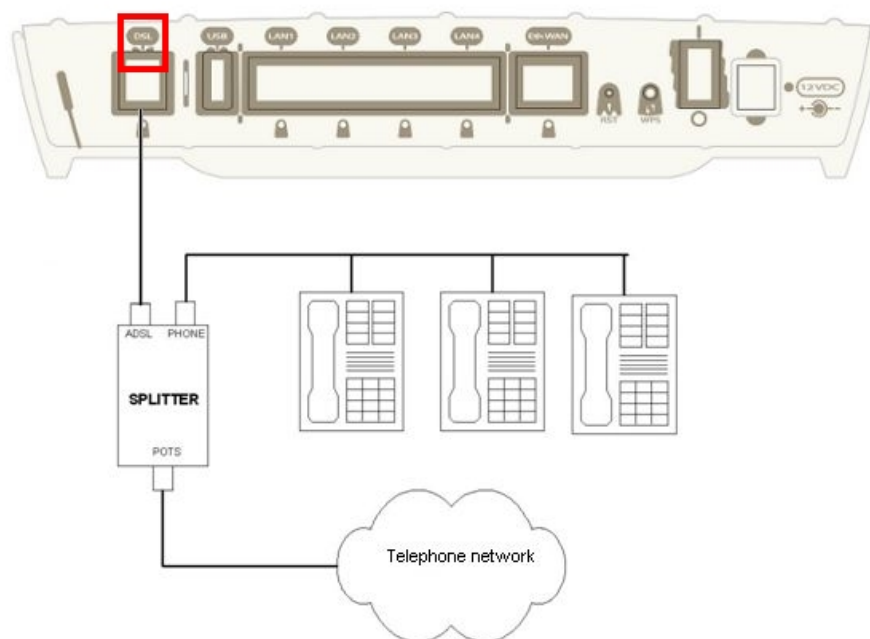

Fig. 14: ADSL installation with splitter

#### Microfilters

Some DSL operating modes (e.g., G.Lite or ITU G.922.2) can use basic service devices (PSTN or ISDN) connected to the same line, by using a **microfilter**. This device ensures the DSL signal does not reach the basic service device and undesired signals generated by the router do not interfere with the DSL signal.

A typical installation with microfilters is shown in Figure 15



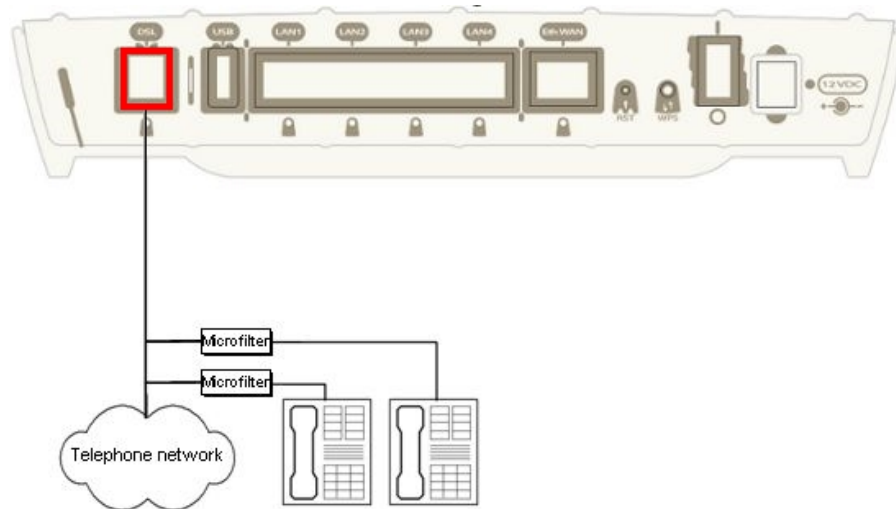

Fig. 15: ADSL installation with microfilters

### 3.6.4 WWAN Antenna Connection (Cell connector)

The **Teldat Connect 104V** has three connectors for WWAN Cellular antennas. To assemble and disassemble (remove) the antennas, simply screw/unscrew them into/from the connectors labeled *Cell*, on the front panel of the router.

Installing these antennas on the **Teldat Connect 104V** is essential to improve the quality of the signal received and transmitted by the cellular model.

The router must have a plug-in Wireless WAN card and the corresponding software license to ensure operability. The Wireless WAN module can be purchased at a later date. The manual accompanying this module provides instructions on installation, as well as for the corresponding antenna cables.



#### Note

For optimum performance, always install the WWAN/CELL antennas.

The cellular interface is only operative if you have installed the corresponding software license.

Some cellular telephony technologies use antenna diversity to improve the quality of the signal received (HSUPA, CDMA EV-DO, LTE, etc.). For this reason, the **Teldat Connect 104V** router incorporates various WWAN connectors.

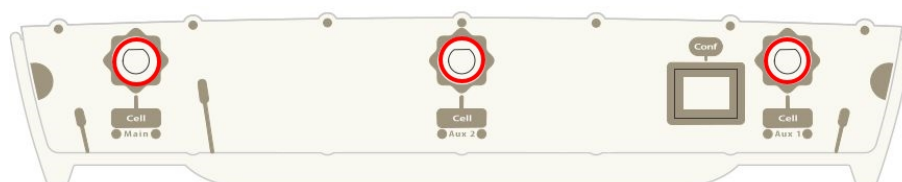

Fig. 16: WWAN Antennas

When the *Main* and *Aux 1* antennas are not directly connected to the router, but are installed through extension cords, the minimum distance between the two must be 7cm. Maximum recommended distance is 25cm.

For optimum performance, use the radio frequency accessories (antennas and cables) recommended by Teldat.

Teldat has a wide range of accessories (90° mount antennas, antennas for exterior installation, antennas for ceiling installation, extension cables, etc.) to install the routers in different locations.

#### 3.6.4.1 Placing the Antenna

The orientation of the antenna and its location with respect to other wireless devices and radiation sources (such as communication devices, personal computers, etc.) can significantly influence device performance.

Antennas transmit and receive radio signals. Their performance is also affected by environmental factors (such as

the distance between the router and the base station), physical obstacles and other interferences due to radio frequencies (RF).

For optimum coverage, follow these steps:

- Whenever possible, place the antenna where there are no physical obstacles. Obstacles between the antenna and the base station degrade the wireless signal. Place the antenna above ground level facing the nearest base station.
- The density of materials also affects antennas. Place them away from any type of wall, metal screens, mirrors, etc.
- Do not place the antenna near columns, as they may throw shadows and reduce the coverage area.
- Keep the antenna away from metal ducts such as canalization, air-conditioning etc.
- Please bear in mind that other wireless devices (such as telephones, microwaves, etc.) can temporarily interfere with the quality of the wireless signal.
- We do not recommend installing antennas in racks that contain communication devices, computers, etc. Use an extension cable and place the antenna outside.

The following recommendations are applicable to all wireless devices:

- Do not touch or move the antenna while the router is transmitting or receiving.
- When the antenna is transmitting, do not touch any equipment that contains devices that radiate very close to, or touching, any exposed part of the body (particularly face and eyes).
- Do not install the router in areas where the atmosphere is potentially explosive.
- Wireless devices can cause interferences in other devices. Do not use the router in areas where medical equipment is installed.
- To ensure compliance with Directive R&TTE 1999/5/EC, the router must be at least 15 cm away from a person's body when operating.

### 3.6.5 Wireless LAN Antenna Connection (Wi-Fi connectors)

The **Teldat Connect 104V** router has two RF antenna connectors for an external antenna to improve the quality of the signal received and transmitted by the Wireless LAN module.

This module is internal and can be activated by purchasing the appropriate software license. To assemble and disassemble (remove) the antennas provided with the router, just screw/unscrew them into/from the connectors labeled *Wi-Fi* (located on the router's side panels).

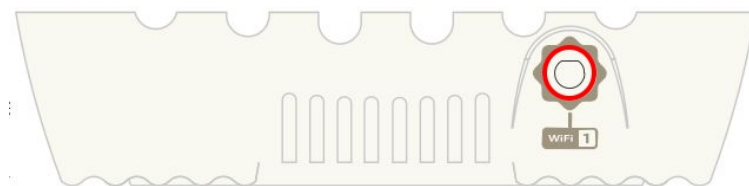

Fig. 17: Wi-Fi Antenna 1

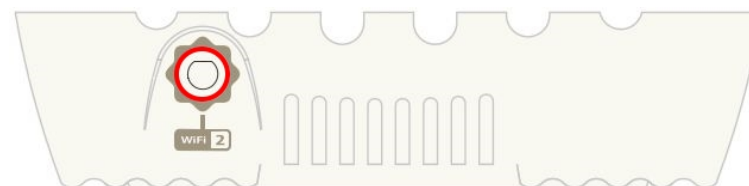

Fig. 18: Wi-Fi Antenna 2

### 3.6.6 Connecting a 3G USB (USB connector)

The **Teldat Connect 104V** has a USB HOST 2.0 Type A connector interface, compatible with 3G USB modems. The interface can be activated by purchasing the appropriate software license.

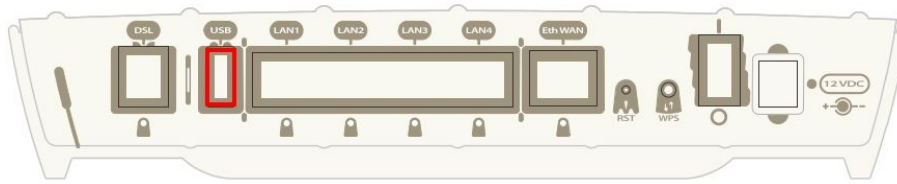

Fig. 19: USB 3G Connector

### 3.7 Installing the SIM card

The **Teldat Connect 104V** router has a Wireless WAN interface that needs a SIM card to operate. Certain services (CDMA) provided by several carriers in some countries do not require SIM cards.

To access the cellular module SIM tray, open the flap located on the underside of the router. This is shown in the following figure:

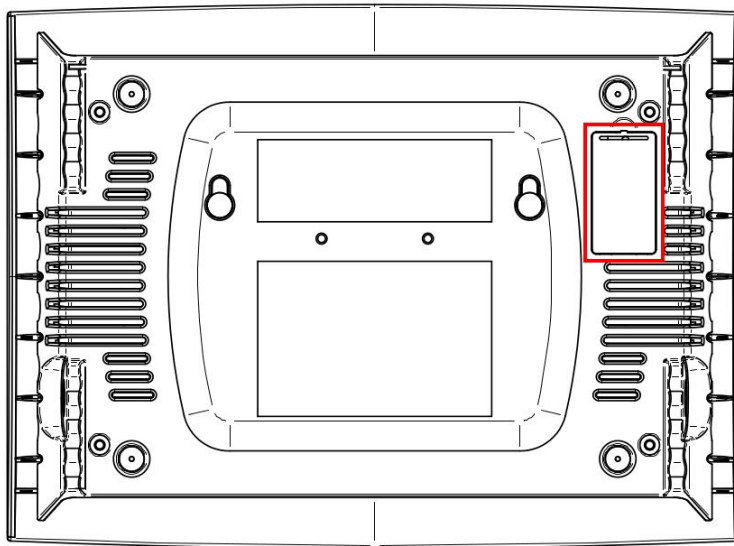

Fig. 20: WWAN cellular module SIM tray

Insert the SIM as follows: first, locate the slot and remove the flap. The SIM tray is now visible. Then carry out the following steps:

- (1) Using a fingernail, pull the visible flap slightly back towards the OPEN arrow in order to release it from the plastic lip holding it.
- (2) Open the tray.
- (3) Insert the SIM card inside the tray, paying particular attention to its edges. If it isn't correctly inserted, the tray won't close.
- (4) Return the tray holding the SIM card to its original position.
- (5) Again, using a fingernail, pull the top flap slightly back (as in step 1) so it gently slides back under the plastic lip without damaging the holder. The card is now securely held.

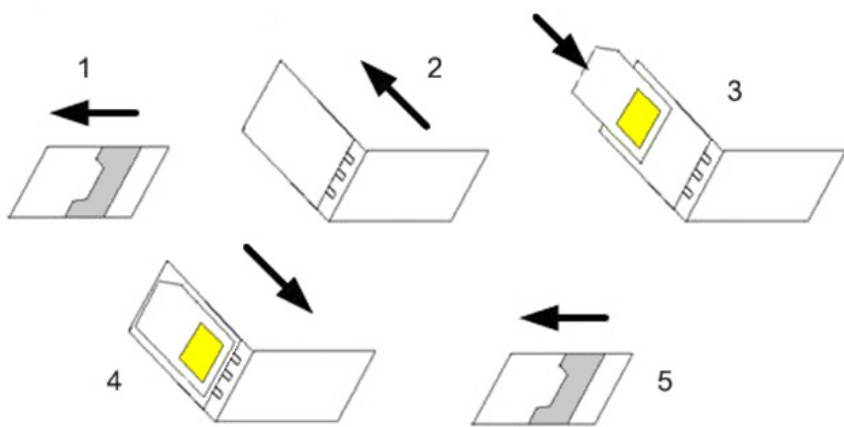

Fig. 21: Instructions to insert the SIM in the WWAN module

## Appendix A Model information

Currently, there are several devices with different WWAN cellular module configurations. The following table shows the relationship between the trademark, the regulatory model and its functionalities.

Part Number	Trademark	Regulatory Name	Description
RCTVH201	Teldat Connect-104V	TLDPV00A1	Teldat Connect-104V: 1xVDSL2/ADSL2+, 4xGE, 802.11bgn
RCTVH201SEC	Teldat Connect-104V-SEC	TLDPV00A1	Teldat Connect-104V-SEC: 1xVDSL2/ADSL2+, 4xGE, 802.11bgn, IPSec
RCTVH203	Teldat Connect-104V-H+	TLDPV01A1	Teldat Connect-104V-H+: 1xVDSL2/ADSL2+, 4xGE, 802.11bgn, HSPA+
RCTVH203SEC	Teldat Connect-104V-H+-SEC	TLDPV01A1	Teldat Connect-104V-H+-SEC: 1xVDSL2/ADSL2+, 4xGE, 802.11bgn, HSPA+, IPSec
RCTVH204	Teldat Connect-104V-LE	TLDPV02A1	Teldat Connect-104V-LE: 1xVDSL2/ADSL2+, 4xGE, 802.11bgn, LTE (Europe)
RCTVH204SEC	Teldat Connect-104V-LE-SEC	TLDPV02A1	Teldat Connect-104V-LE-SEC: 1xVDSL2/ADSL2+, 4xGE, 802.11bgn, LTE (Europe), IPSec

## Appendix B Appendix

### B.1 Troubleshooting

The following table can help you solve problems when installing the router. If you cannot solve the problem, contact your dealer for more information.

Symptom	Solution
None of the LEDs light up on the router.	Check the power supply to the router (power source, ON/OFF switch, main power outlet).
You have forgotten the router's access password.	Ignore the configuration using the <i>RST Button</i> on page 10 (as explained in the relevant section).
The <i>DSL</i> LED never lights up in green.	If the router has an available xDSL interface, check the connection to the network, or to the splitter, and make sure the connected telephone line supports xDSL.
The <i>Eth WAN</i> LED never lights up in green.	Check the Ethernet cable and the connection to the network.
The <i>Wi-Fi</i> LED never lights up in green.	Check the router's configuration and that for the remote station(s). Check the appropriate license is available for use.
The <i>USB</i> LED never lights up in green.	Check that the device inserted in the USB connector is supported by the router. Please visit the Teldat website <a href="http://www.teldat.com">www.teldat.com</a> to get the list of compatible 3G USB modems. Check the appropriate license is available for use.

### B.2 Updating the software

The **Teldat Connect 104V** router can be updated to newer versions. Please contact your dealer for further details on new versions.

There are several ways to update a Teldat router. Please see manual *Dm748-I Software Updating* for further information.

The software required to update Teldat routers is supplied in a format known as **distribution**. This consists of a single file containing everything necessary to update your device, as well as in-depth information on content.

The **Teldat Connect 104V** router incorporates independent modules for the Wireless WAN interface. Generally, the firmware for the modules is independent from the router software. There is an upgrade file for each Wireless WAN module. Please ask your distributor for the correct upgrade file (according to the module in your device). The Cellular Interface manual (document *Dm781-I*) shows you how to upgrade the module.

## B.3 Connectors

### B.3.1 LAN Connector

#### LAN Connector

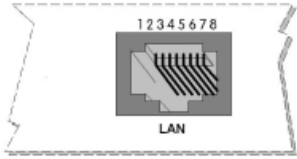
RJ45 LAN	RJ45 PINOUT	FE Signals	GE Signals
	1	BI-DA+	BI-DA+
	2	BI-DA-	BI-DA-
	3	BI-DB+	BI-DB+
	4	--	BI-DC+
	5	--	BI-DC-
	6	BI-DB-	BI-DB-
	7	--	BI-DD+
	8	--	BI-DD-

### B.3.2 WAN Connector

#### WAN Connector

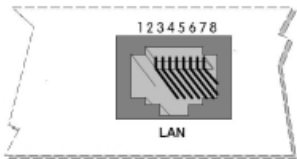
RJ45 WAN	RJ45 PINOUT	FE Signals	GE Signals
	1	BI-DA+	BI-DA+
	2	BI-DA-	BI-DA-
	3	BI-DB+	BI-DB+
	4	--	BI-DC+
	5	--	BI-DC-
	6	BI-DB-	BI-DB-
	7	--	BI-DD+
	8	--	BI-DD-

### B.3.3 WWAN/Cell Connector (female)

#### WWAN/Cell Connector

	PINOUT	ANT
	<b>Internal</b>	RF in/out
	<b>External</b>	GND

### B.3.4 WLAN/Wi-Fi Connector (male)

#### WLAN/Wi-Fi Connector

	PINOUT	ANT
	<b>Internal</b> <b>External</b>	RF in/out GND

### B.3.5 DSL Connector

#### DSL Connector

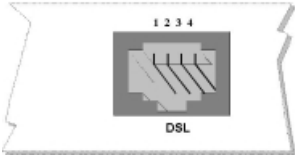
RJ11 DSL	RJ11 PINOUT	DSL
	<b>1</b> <b>2</b> <b>3</b> <b>4</b>	Joined to 2 Line Line Joined to 3

### B.3.6 USB Connector

#### USB Connector

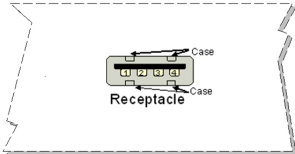
USB Type A	PINOUT	USB
	<b>1</b> <b>2</b> <b>3</b> <b>4</b> <b>Shell</b>	VCC DATA- DATA+ GND Shield



### B.3.7 Configuration Connector

#### Configuration connector

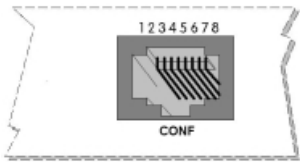
RJ45 CONFIGURATION	RJ45 PINOUT	CONF
	1	--
	2	RxD
	3	GND
	4	--
	5	--
	6	GND
	7	TxD
	8	--

### B.3.8 Power Supply Connector

#### Power Supply Connector

	PINOUT	ANT
	<b>Internal</b>	POSITIVE
	<b>External</b>	NEGATIVE

## B.4 Technical Specifications

### B.4.1 Hardware Architecture

PROCESSORS	Broadcom BCM963168
MEMORY	128 Mbytes in SDRAM.
STORAGE UNIT	FLASH Memory (32 Mbytes).

### B.4.2 LAN Interface

PROTOCOLS	Ethernet (802.3).
PORTS	4 port switch managed with MDI/MDX autodetection.
SPEED	10/100/1000 Mbps (BaseT).
CONNECTOR	RJ45 female.

### B.4.3 WAN Interface

STANDARDS	Ethernet (802.3).
SPEED	10/100/1000 Mbps (BaseT)
CONNECTOR	RJ45 female.

#### B.4.4 DSL Interface

STANDARDS	Please see manual <i>Dm741-I</i>
SPEED	Please see manual <i>Dm741-I</i>
CONNECTOR	RJ11 female.

#### B.4.5 Wireless WAN Interface

STANDARDS	GPRS, UMTS, HSDPA, HSUPA, HSPA+, LTE ... Depends on the Wireless WAN interface version embedded.
SPEED	Depends on the Wireless WAN interface version embedded. Please check the module manual.
CONNECTOR	2 RF SMA Female per module.
ANTENNA	Depends on the type of Wireless WAN module. Please check the antenna catalog for Cellular interfaces.

#### B.4.6 Wireless LAN Interface

STANDARDS	802.11abgn
FREQUENCY	2.4 GHz / 5 GHz
SPEEDs	Supports all mandatory data rates specified in IEEE 802.11n up to 300 Mbps, and the legacy rates specified in IEEE 802.11a/b/g including 1, 2, 5.5, 6, 9, 11, 12, 18, 24, 36, 48, and 54 Mbps
CONNECTOR	2 RF SMA Male

#### B.4.7 USB Interface

3G USB MODEMS	Please visit the Teldat website <a href="http://www.teldat.com">www.teldat.com</a> to get a list of supported 3G USB modems.
SPEED	The interface complies with the USB 2.0 (480 Mbps) standard; the end speed depends on the 3G/WWAN USB modem used.
CONNECTOR	USB Type A

#### B.4.8 Configuration Interface

LOCAL TERMINAL	V.24 9.600-8-N-1-without flow control.
CONNECTOR	RJ45 female on the device front panel.

### B.4.9 Power Supply

INPUT VOLTAGE	+12V DC.
INPUT CURRENT	1200 mA
JACK	5.5 mm
INTERNAL PIN	2.5 mm

### B.4.10 External Power Supply

INPUT VOLTAGE	100-240V AC
INPUT CURRENT	1.0 A
INPUT FREQUENCY	50-60 Hz

### B.4.11 Dimensions and weight





TYPE	Desktop.
LENGTH x WIDTH x HEIGHT	242 x 179 x 48 mm.
WEIGHT	0.8 Kg.

### B.4.12 Environmental Specifications

TEMPERATURE	OPERATING NORMALLY: 0°C to 40°C STORED: -30°C to 85°C
RELATIVE HUMIDITY	On: 5% to 90%

## Appendix C Regulatory compliance and Safety information

### C.1 Translated Safety Warnings

	The screws must go into a wall stud (wood) or a wall anchor of the appropriate type for the wall. Screws into drywall are not strong enough to support the router.
	Los tornillos deben ir atornillados en un taco de pared (de madera o del tipo adecuado según la clase de pared). Los tornillos que se montan directamente en los paneles de yeso no son lo bastante resistentes para soportar el router.
	If you install the screws in drywall, use hollow-wall anchors (8 mm – 5/16 inch) to secure the screws. If the screws are not properly anchored, the strain of the cables connected to the router back panel could pull the router from the wall.
	Si instala los tornillos en paneles de yeso, utilice tacos de pared hueca (8 mm - 5/16 pulgadas) para fijar los tornillos. Si los tornillos no están bien anclados, la tensión de los cables conectados al panel posterior del router podría hacer que el router se cayera de la pared.
	The equipment must be used with the power supply provided by the manufacturer, or equivalent.
	El equipo debe ser usado con la fuente de alimentación proporcionada por el fabricante, o una equivalente.
	The electric current in power cables, telephone lines and communication cables is dangerous. To prevent electric shocks, before installing, handling or opening the equipment covers, connect and disconnect the cables following the steps set forth in the relevant sections.
	La tensión eléctrica de los cables de alimentación, de los cables de la línea telefónica y de los cables de comunicación es peligrosa. Para evitar descargas, antes de instalar, mover o abrir las cubiertas de este equipo, conecte y desconecte los cables siguiendo el orden que se detalla en los apartados relevantes.
	All interconnected communication devices should be plugged to THE SAME GROUNDED POWER OUTLET, which should at the same time be of good quality (lower than 10 ohms). Whether the workplace is provided with an uninterrupted power supply system (UPS), regulated supply or it is independent from the rest (such as lighting, etc.); it is highly recommended that all data devices should be connected to the same power source. This will avoid operating and premature aging problems of drivers and other components.
	Todos los equipos de comunicaciones interconectados deberán estar unidos a UNA MISMA TOMA DE TIERRA, a ser posible de buena calidad (inferior a 10 ohmios). Si la instalación está dotada de un Sistema de Alimentación Ininterrumpida (SAI), alimentación estabilizada, o bien es independiente del resto (alumbrado, etc.), conecte todos los equipos de comunicaciones a la misma fuente de alimentación. Así, se ahorrará problemas de funcionamiento y envejecimiento prematuro de drivers y demás componentes.

### C.2 PSU Energy Efficiency

According to Commission Regulation (EU) 2019/1782 laying down ecodesign requirements for external power supplies pursuant to Directive 2009/125/EC of the European Parliament and of the Council and repealing Commission Regulation (EC) No 278/2009, the instruction manuals for end-users shall include the following information:

<i>Model</i>	DA-60N12
--------------	----------

<i>Manufacturer Name</i>	ASIAN POWER DEVICES INC. (APD)
<i>Manufacturer Address</i>	NO.5 LANE 83. LUNG-SOU ST, TAO-YUAN CITY, TAIWAN R.O.C.
<i>Input Voltage</i>	100-240 Vac
<i>Input AC frequency</i>	50-60 Hz
<i>Output voltage</i>	12.0 V
<i>Output current</i>	5.0 A
<i>Output power</i>	60.0 W
<i>Average active efficiency</i>	88.3%
<i>Efficiency at low load (10%)</i>	87.2%
<i>No-load power consumption</i>	0.12 W

## C.3 Compliance

### C.3.1 FCC Statement

#### C.3.1.1 Federal Communications Commission Interference Statement (FCC)

This equipment has been tested and found to comply with the limits for a Class B digital device, pursuant to Part 15 of the FCC Rules. These limits are designed to provide reasonable protection against harmful interference in a residential installation. This equipment generates, uses and can radiate radio frequency energy and, if not installed and used in accordance with the instructions, may cause harmful interference to radio communications. However, there is no guarantee that interference will not occur in a particular installation. If this equipment does cause harmful interference to radio or television reception, which can be determined by turning the equipment off and on, the user is encouraged to try to correct the interference by one of the following measures:

- Reorient or relocate the receiving antenna.
- Increase the separation between the equipment and receiver.
- Connect the equipment into an outlet on a circuit different from that to which the receiver is connected.
- Consult the dealer or an experienced radio/TV technician for help.

**FCC Caution:** Any changes or modifications not expressly approved by the party responsible for compliance could void the user's Authority to operate this equipment.

This device complies with Part 15 of the FCC Rules. Operation is subject to the following two conditions: (1) This device may not cause harmful interference, and (2) this device must accept any interference received, including interference that may cause undesired operation.

For product available in the USA/Canada market, only channel 1~11 can be operated. Selection of other channels is not possible.

This device and its antennas(s) must not be co-located or operating in conjunction with any other antenna or transmitter except in accordance with FCC multi-transmitter product procedures.

This device is going to be operated in 5.15~5.25GHz frequency range, it is restricted in indoor environment only.



#### Important

#### FCC Radiation Exposure Statement:

This equipment complies with FCC radiation exposure limits set forth for an uncontrolled environment.

This equipment should be installed and operated with minimum distance 20cm between the radiator & your body.

### C.3.1.1.1 FCC 68

#### *Customer Information*

This equipment complies with Part 68 of the FCC rules and the requirements adopted by the ACTA. *At the bottom* of this equipment, there is a label that contains, among other information, a [US: TLDDL01BTLDPV00A1] product identifier. If requested, this number must be provided to the telephone company.

If this equipment [Enterprise Router] causes harm to the telephone network, the telephone company will notify you in advance that a temporary discontinuance of service may be required. But if advance notice isn't practical, the telephone company will notify the customer as soon as possible. Also, you will be advised of your right to file a complaint with the FCC if you believe it is necessary.

The telephone company may make changes in its facilities, equipment, operations or procedures that could affect the operation of the equipment. If this happens the telephone company will provide advance notice in order for you to make necessary modifications to maintain uninterrupted service.

If you experience trouble with this equipment, you disconnect it from the network until the problem has been corrected or until you are sure that the equipment is not malfunctioning.

Please follow the repair instructions, if any (e.g. battery replacement section). Otherwise, do not alternate or repair any parts of the device that were not specified.

If the telephone company requests information on what equipment is connected to their lines, inform them of:

- (a) The telephone number that this unit is connected to,
- (b) The ringer equivalence number [01]
- (c) The USOC jack required [RJ11C], and
- (d) The FCC Registration Number [TLD]

Items (b) and (d) are indicated on the label. The ringer equivalence number (REN) is used to determine how many devices can be connected to your telephone line. In most areas, the sum of the RENs of all devices on any one line should not exceed five (5.0). If too many devices are attached, they may not ring properly.

#### *Service Requirements*

In the event of equipment malfunction, all repairs must be performed by our Company or an authorized agent. It is the responsibility of users requiring service to report the need for service to our Company or to one of our authorized agents. Service can be facilitated through our office at:

**Company Name:** Teldat Corp

**Contact Name:** Ignacio Loizaga

**Address:** 15466 Los Gatos Blvd

Suite #109-335

Los Gatos CA 95032

**Telephone No:** 408 892 9363

**Fax No:** 408-608-2172

**Email:** iloizaga@teldat.com

### C.3.1.2 IC Statement

#### C.3.1.2.1 CAN ICES-3 (B)/NMB-3(B)

This device complies with Industry Canada license-exempt RSS standard(s). Operation is subject to the following two conditions: (1) this device may not cause interference, and (2) this device must accept any interference, including interference that may cause undesired operation of the device.

*Le présent appareil est conforme aux CNR d'Industrie Canada applicables aux appareils radio exempts de licence. L'exploitation est autorisée aux deux conditions suivantes : (1) l'appareil ne doit pas produire de brouillage, et (2) l'utilisateur de l'appareil doit accepter tout brouillage radioélectrique subi, même si le brouillage est susceptible d'en compromettre le fonctionnement.*

For product available in the USA/Canada market, only channel 1~11 can be operated. Selection of other channels is not possible.

*Pour les produits disponibles aux États-Unis / Canada du marché, seul le canal 1 à 11 peuvent être exploités. Sélection d'autres canaux n'est pas possible.*

This device and its antennas(s) must not be co-located or operating in conjunction with any other antenna or transmitter except in accordance with IC multi-transmitter product procedures.

*Cet appareil et son antenne (s) ne doit pas être co-localisés ou fonctionnement en association avec une autre antenne ou transmetteur.*

The device could automatically discontinue transmission in case of absence of information to transmit, or operational failure. Note that this is not intended to prohibit transmission of control or signaling information or the use of repetitive codes where required by the technology.

*Le dispositif pourrait automatiquement cesser d'émettre en cas d'absence d'informations à transmettre, ou une défaillance opérationnelle. Notez que ce n'est pas l'intention d'interdire la transmission des informations de contrôle ou de signalisation ou l'utilisation de codes répétitifs lorsque requis par la technologie.*

The device for the band 5150-5250 MHz is only for indoor usage to reduce potential for harmful interference to co-channel mobile satellite systems.

*Les dispositifs fonctionnant dans la bande 5150-5250 MHz sont réservés uniquement pour une utilisation à l'intérieur afin de réduire les risques de brouillage préjudiciable aux systèmes de satellites mobiles utilisant les mêmes canaux.*



#### Important

#### IC Radiation Exposure Statement:

This equipment complies with the IC RSS-102 radiation exposure limits for an uncontrolled environment. This equipment should be installed and operated keeping a minimum distance of 20cm between the radiator & your body.

*Déclaration d'exposition aux radiations au Canada:*

*Cet équipement est conforme aux limites d'exposition aux rayonnements IC établies pour un environnement non contrôlé.*

*Cet équipement doit être installé et utilisé avec un minimum de 20 cm de distance entre la source de rayonnement et votre corps.*

#### NOTE:

Only for the Canadian Industry:

Under Industry Canada regulations, this radio transmitter may only operate using an antenna of a type and maximum (or lesser) gain approved for the transmitter by the Canadian Industry.

To reduce potential radio interference to other users, the antenna type and its gain should be so chosen that the

equivalent isotropically radiated power (e.i.r.p.) is not more than that necessary for successful communication.

This radio transmitter (IC: 11046A-TLDPV00A1) has been approved by Canadian Industry to operate with the antenna types listed below with the maximum permissible gain and required antenna impedance for each type of antenna indicated.

The use of antenna types not included in this list, having a greater gain than the maximum value admitted for that type, are strictly prohibited:

Model	Impedance	Gain	Power
EDA-8709-25GR2-A9	50 Ohm Nominal	2dBi (Typ.)	1W

**IC Telecom Statement:**

This product meets the applicable Canadian Industry technical specifications.

*Le présent matériel est conforme aux spécifications techniques applicables d'Industrie Canada.*

The Ringer Equivalence Number (REN) is an indication of the maximum number of devices allowed to be connected to a telephone interface. The termination of an interface may consist of any combination of devices subject only to the requirement that the sum of the RENs of all the devices not exceed five.

*L'indice d'équivalence de la sonnerie (IES) sert à indiquer le nombre maximal de terminaux qui peuvent être raccordés à une interface téléphonique. La terminaison d'une interface peut consister en une combinaison quelconque de dispositifs, à la seule condition que la somme d'indices d'équivalence de la sonnerie de tous les dispositifs n'excède pas cinq.*